

Shrink Fit heads are interchangeable between inch and metric. For metric refer to page 22.

### ③ ④ ⑤ Shrink Fit System

Millstar's Shrink System offers versatility, strength and accuracy. The carbide shanks and heads are interchangeable between inch and metric versions. Metric heads fit on inch shanks and inch heads fit on metric shanks. The 12mm and 1/2 inch shanks will accept any head that is the same diameter or smaller (see chart for connectivity). The carbide shank offers strength and

rigidity and the shrink tolerances offer better accuracy than screw on type systems. These tools are designed for high speed machining and hard metal machining and will allow for better tool life as well as better surface finishes.



All diameters are available in short and long length versions.

### Shanks for Shrink Fit Heads

Tool Ordering No.	Shank Ø D1	Length L1	Length L2
CSS-0500-2.9-T1	.5000	2.900	.600
CSS-0500-4.9-T1	.5000	4.900	.600
CSS-0625-4.1-T2	.6250	4.100	.650
CSS-0625-7.1-T2	.6250	7.100	.650
CSS-0750-3.8-T3	.7500	3.800	.700
CSS-0750-6.8-T3	.7500	6.800	.700

### Shrink Fit Heads

Tool Ordering No.	D1	Length L1	Length L2	Use With Insert Style
CHTAV-0250-T1	.460	1.700	.879	⑤
CHTAV-0312-T1	.460	1.700	.827	⑤
CHTA-0375-T1	.460	1.700	.845	③/④
CHY-0500-T1	.460	1.700	.857	③
CHY-0625-T2	.550	1.500		③
CHY-0750-T3	.675	1.900		③
CHF-0500-T1	.460	1.700	.857	④
CHF-0625-T2	.550	1.500		④
CHF-0750-T3	.675	1.900		④

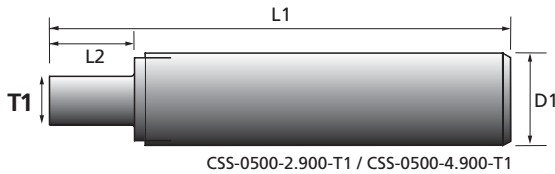

Used with Shrink Fit Heads:  
 CHTAV-0250-T1 CHTAV-0312-T1 CHTA-0375-T1 CHY-0500-T1  
 CHF-0500-T1

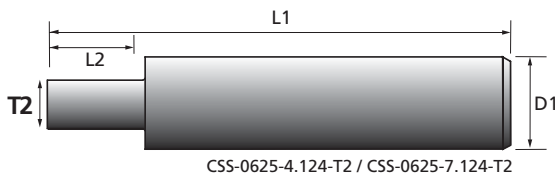
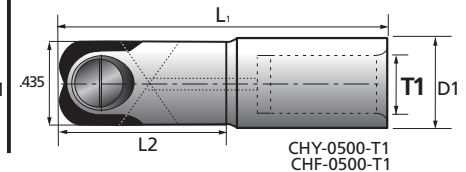
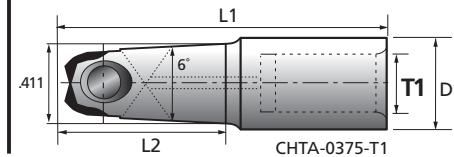
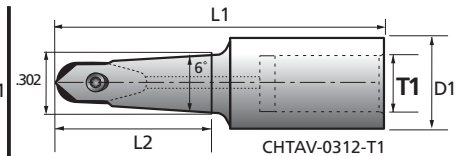
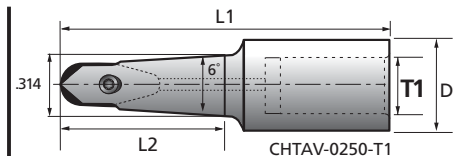

Used with Shrink Fit Heads:  
 CHF-0625-T2 CHY-0625-T2

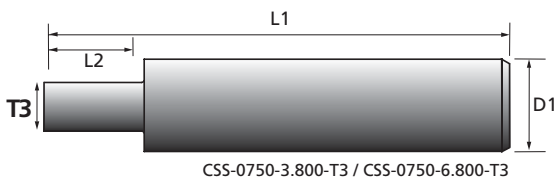
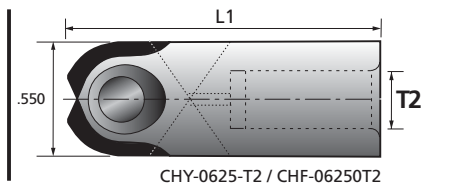

Used with Shrink Fit Heads:  
 CHF-0750-T3 CHY-0750-T3

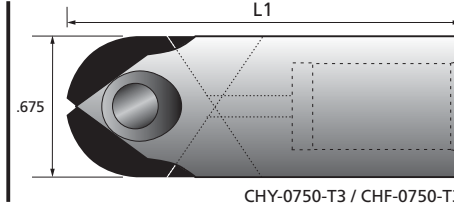

Shrink Fit heads are interchangeable between inch and metric. For inch refer to page 10.



### ③ ④ ⑤ Shrink Fit System

Millstar's Shrink System offers versatility, strength and accuracy. The carbide shanks and heads are interchangeable between inch and metric versions. Metric heads fit on inch shanks and inch heads fit on metric shanks. The 12mm and 1/2 inch shanks will accept any head that is the same diameter or smaller (see chart for connectivity). The carbide shank offers strength and

rigidity and the shrink tolerances offer better accuracy than screw on type systems. These tools are designed for high speed machining and hard metal machining and will allow for better tool life as well as better surface finishes.

All diameters are available in short and long length versions.

### Shanks for Shrink Fit Heads

Tool Ordering No.	Shank Ø D1	Length L1	Length L2
CSS-12-73.6-T1	12	73,6	15,24
CSS-12-124.4-T1	12	124,4	15,24
CSS-16-104.8-T2	16	104,8	16,51
CSS-16-180.9-T2	16	180,8	16,51
CSS-20-96.5-T3	20	96,5	17,78
CSS-20-172.7-T3	20	172,7	17,78

### Shrink Fit Heads

Tool Ordering No.	D1	Length L1	Length L2	Use With Insert Style
CHTAV-06-T1	11,7	43,2	22,3	⑤
CHTAV-08-T1	11,7	43,2	20,9	⑤
CHTA-10-T1	11,7	43,2	21,5	③/④
CHY-12-T1	11,7	43,2	21,5	③
CHY-16-T2	14,0	38,2		③
CHY-20-T3	17,1	48,3		③
CHF-12-T1	11,7	43,2	21,5	④
CHF-16-T2	14,0	38,2		④
CHF-20-T3	17,1	48,3		④

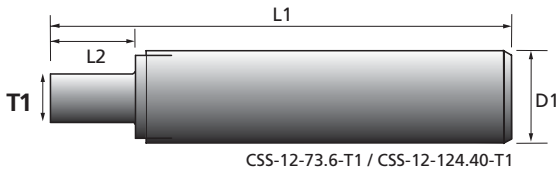

CSS-12-73.6-T1 / CSS-12-124.40-T1

Used with Shrink Fit Heads:  
 CHTAV-06-T1 CHTAV-08-T1 CHTA-10-T1 CHTAFV-06-T1  
 CHY-12-T1 CHF-12-T1  
 CHTAFV-08-T1 CHTAF-10-T1

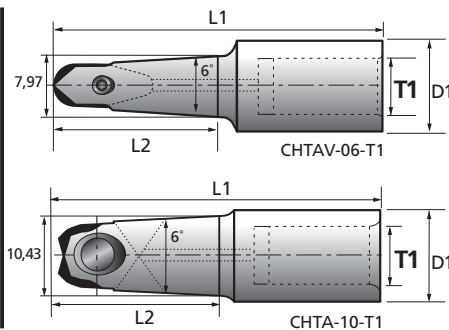

CHTAV-06-T1

CHTA-10-T1

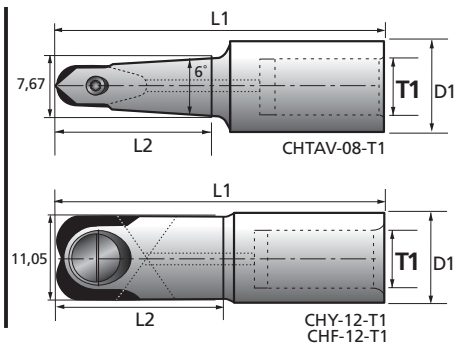

CHY-12-T1  
CHF-12-T1

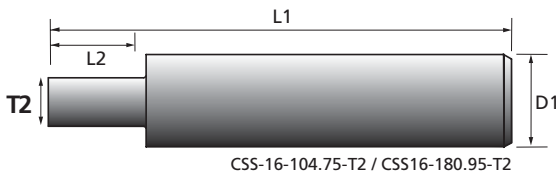

CSS-16-104.75-T2 / CSS16-180.95-T2

Used with Shrink Fit Heads:  
 CHF-16-T2 CHY-16-T2

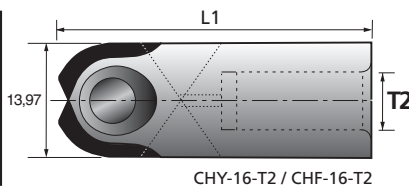

CHY-16-T2 / CHF-16-T2

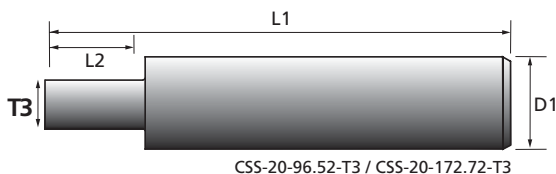

CSS-20-96.52-T3 / CSS-20-172.72-T3

Used with Shrink Fit Heads:  
 CHF-20-T3 CHY-20-T3

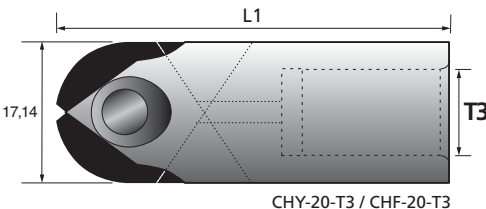

CHY-20-T3 / CHF-20-T3